



Robotics at MARYLAND

Partnerships and Opportunities

- **Personal Note**

- Competition brings out the best in us. It compels us to learn and innovate in new and exciting ways. Robotics at Maryland (R@M) seeks to challenge its members every year by designing and improving our competition vehicles. This way, we give our members out of classroom experience solving real-world problems and developing skills that set them apart from their peers. This educational development is expensive. In order to stay running from year to year, we need support from outside sponsors. I would like to thank our sponsors, past and present, for helping us with our education and turning our ideas into reality.

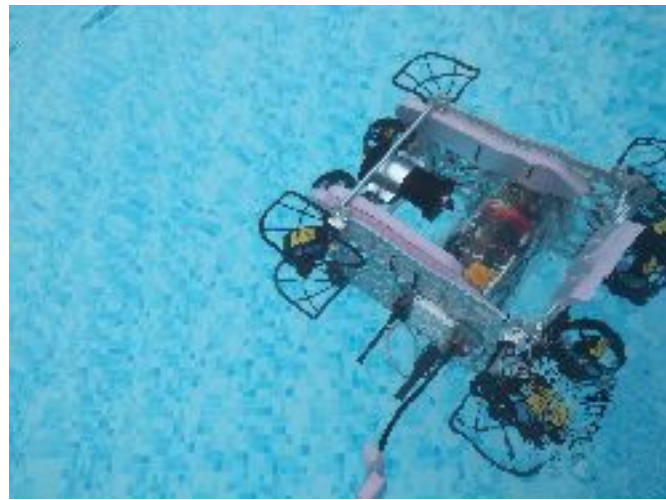

-John Rogers, Treasurer 2016-2017

- **Who are We?**

- Robotics@Maryland is a student-run robotics team at the University of Maryland, College Park campus. We are a diverse mix of passionate students from a wide variety of majors, each with the goal of designing and creating robots. The team's experienced core leadership is supported by younger members anxious to create an impact in the autonomous robotics space. The culture is similar to what you might expect at a startup—a small team working to make a difference. However, we would be remiss if we did not mention Tortuga as one of our key members. Originally designed and built in 2007, R@M's autonomous underwater vehicle has undergone several upgrades over the years. However, through its various iterations, Tortuga remains just as symbolic to our current team as it was to the original members of Robotics@Maryland.

- **What Do We Do?**

- Every summer, Robotics@Maryland competes in the international RoboSub Competition hosted by the U.S. Office of Naval Research (ONR) and the Association for Unmanned Vehicle Systems International (AUVSI). Over 35 teams hailing from top universities around the globe compete in a series of tasks aimed at testing the limits both competitors and their robots.

- Our robot is required to navigate through the course by sonar and computer vision, pick up and manipulate objects underwater, and launch torpedoes at a specified target. To add to the challenge, all of it must be done autonomously.
- Each year the tasks change slightly, so teams are always finding new ways to improve on their designs and strategies for the next competition. Our team is a perennial top ten finalist, with the most recent first place overall win coming in 2008. In 2017, we were semifinalists with our new machine, Qubo.

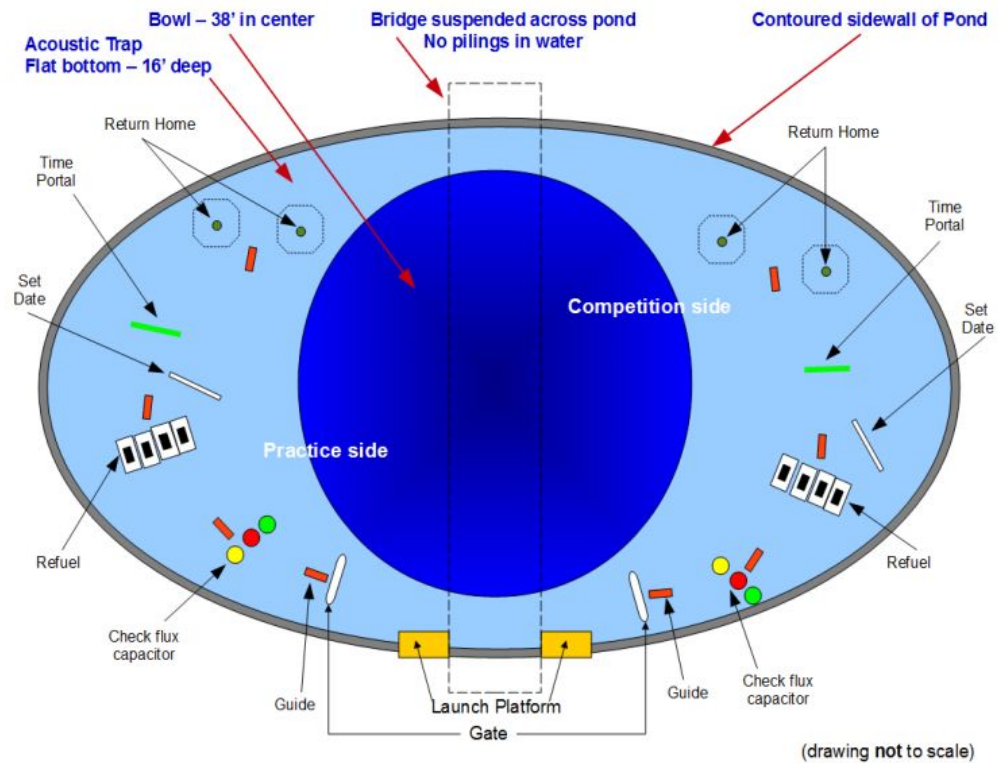

○



○

○

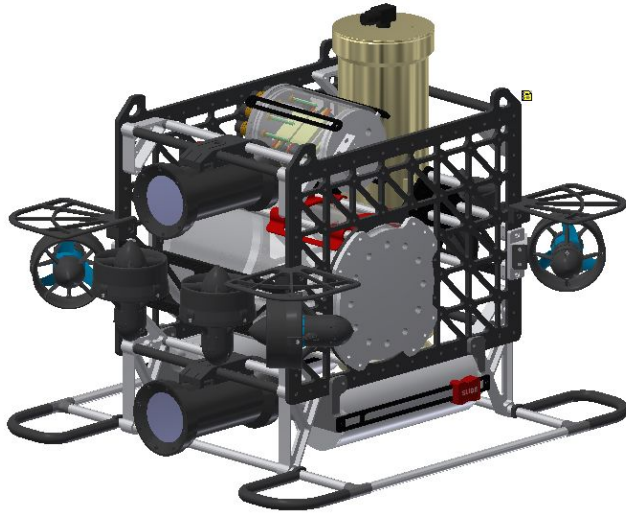

How We Build the Robot

There are five subteams in R@M:

- **Mechanical** builds the structure of the robot and creates the parts that it needs to accomplish its objectives, such as thrusters, Torpedo launchers, and marker droppers. They are also responsible for keeping the electronics dry and cool.
- **Electronics** connects all the parts and makes the boards that let the onboard computer talk to the physical components on the robot. They create the systems that turn the computer's command of "Go forward" into the activation of the correct thrusters.
- **Software** writes the code that collects information from the robot's sensors, and creates the control flow for the robot.
- **Controls** does the math with sensor data to determine where the robot goes and how it will accomplish its objectives.
- Our last department, **Business**, does not build any part of the robot itself but does all the work that makes it possible for us to keep building robots year after year.

- **Why we participate**

- The tasks presented in RoboSub are conceptually simple, but by no means easy. Each component of the vehicle must be designed to be waterproof, fatigue resistant, and neutrally buoyant. All the sensors must be properly calibrated so that the robot will get accurate readings. The robot must be able to properly record and process the data that it receives from its cameras to ensure that it knows where it is going and does not crash along the way. The intricacies in this project challenge us to utilize what we have learned in school in order to compete. It is the challenge of the competition and the experience gained from it that brings members back year after year.

SPONSORSHIP

Why Sponsor R@M?

- There are a myriad of benefits to supporting Robotics at Maryland. Internally, we operate like a startup, but any financial contributions to the organization are classified as charitable gifts to a 501c3 non-profit organization. Also, many of our previous sponsors have had the opportunity to directly connect with focused and motivated students who have gone on to join their organizations in the future. In addition, R@M is an active contributor in design reviews for products we use.

What it Entails

- Robotics at Maryland appreciates of our partners for their expertise shared, time invested, access provided, or financial contributions made. From professors who double check our calculations to corporations that allow us to use their machine shops, small acts are what contribute to R@M's success.

How to Sponsor

- There are numerous ways to support R@M, most often through material support. We emphasize lean design and manufacturing to reduce the cost of our machines. At some points, however, there are issues that require resources beyond our own abilities. Another way to help us is through consulting or technical support. We always appreciate an outside perspective to give us a fresh look at any technical problems that we may encounter. This is why we often host design reviews. They allow us to keep on track with our design goals, make any needed changes or adjustments, and show our sponsors how we are using their support.

Looking to the Future

At R@M, we are always looking to improve on our current design and do more with our robots. Every year the competition gets more and more challenging and we have to adapt to face the obstacles ahead. In order to do this, we will need help. Whether it is from corporate sponsors or from the UMD administration, any resource that you give us will be used to help us make a more effective autonomous vehicle, and to educate students in robotics.

Some Past Partners

UNIVERSITY OF MARYLAND

DEPARTMENT OF
AEROSPACE ENGINEERING

MARYLAND
ROBOTICS CENTER



communications

TC | APPLIED
TECHNOLOGIES



MEMSENSE



The
Institute for
Systems
Research

A. JAMES CLARK
SCHOOL OF ENGINEERING



NORTHROP GRUMMAN



DEPARTMENT OF
ELECTRICAL & COMPUTER
ENGINEERING

DEPARTMENT OF
COMPUTER SCIENCE



TELEDYNE
RD INSTRUMENTS

PTC®

USB FireWire